

February 4, 2009
Chelsea Piers, New York, NY

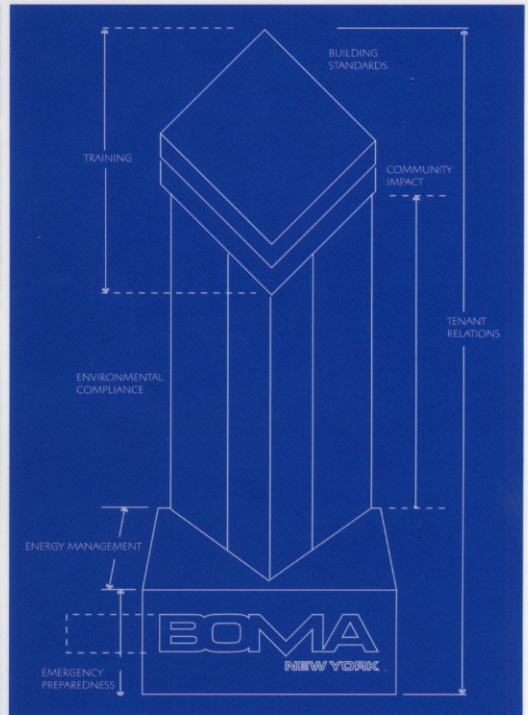

THE 40TH ANNUAL
BOMA / NEW YORK
PINNACLE AWARDS
2008-2009

2008-2009 OPERATING OFFICE BUILDING 500,000 TO 1,000,000 SF

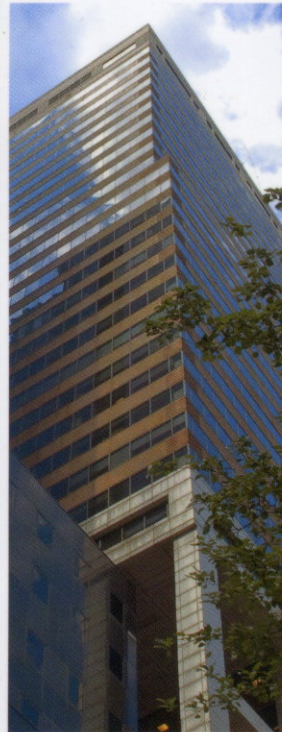
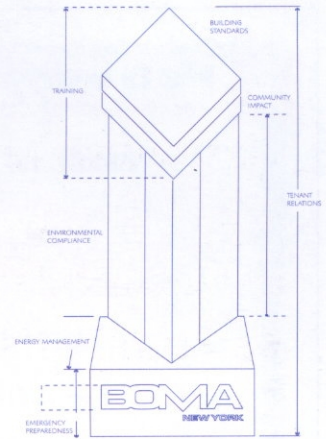

750 Seventh Avenue

Completed in 1990 and one of the first of the major towers to rise in the revitalized Times Square, 750 Seventh Avenue blends ancient, classic and contemporary architectural references in a striking, 36-story Class A office environment.

The 591,169-sf steel frame tower is distinguished by a truly unique facade—a ziggurat-like design featuring upward-sloping glass surfaces, combined with setbacks—that culminates in a mansard roof. Adding to the drama, a 115-foot high stainless steel spire crowns the entire structure, raising its height to 667 feet. Its Post-Modern inspiration is further reflected in the façade materials of reflective “antique silver” windows set in a grid of pale grey ceramic-coated glass. The building’s five exterior “super” signs and two billboards bring it into context with the new Times Square.

The lobby makes a strong corporate statement, mixing traditional and contemporary materials. Plum black granite columns soar 20 feet high to meet a reflective glass ceiling, and contemporary art adorns the walls. Office floors range from 11,750 to 26,500 sf and accommodate, among others, the prestigious law firm of Mendes and Mount, and Morgan Stanley’s technology division.

Ownership and management are committed to sustainability, and are pursuing LEED-EB certification, along with numerous energy initiatives that will ensure the building maintains its high profile as one of New York’s leading office towers.

Owner:

750 Seventh Avenue LLC

Management Firm:

Hines

Property Manager:

Enzo Patenostro

Alarm Service & Fire Command**System:**

Cross-Fire & Security

BMS:

Siemens Building Technologies

Cleaning:

ABM Industries, Inc.

Collins Building Services, Inc.

Doors:

Miric Industries, Inc.

Electric:

Petrocelli Electric Co., Inc.

Elevator:

Otis Elevator

HVAC:

Interstate Mechanical Services, Inc.

Painting:

Albert Pearlman Painting

Plumbing:

K&S Industrial Corporation

Waste Removal:

IESI NY Corporation

Water Treatment:

Nalco

Wood & Metal Maintenance:

Prestige Restoration & Maintenance, LLC

Color listing denotes BOMA/NY membership